

AC Generators

Basic Generator

A basic generator consists of a magnetic field, an armature, slip rings, brushes and a resistive load. The magnetic field is usually an electromagnet. An armature is any number of conductive wires wound in loops which rotates through the magnetic field. For simplicity, one loop is shown. When a conductor is moved through a magnetic field, a voltage is induced in the conductor. As the armature rotates through the magnetic field, a voltage is generated in the armature which causes current to flow. Slip rings are attached to the armature and rotate with it. Carbon brushes ride against the slip rings to conduct current from the armature to a resistive load.

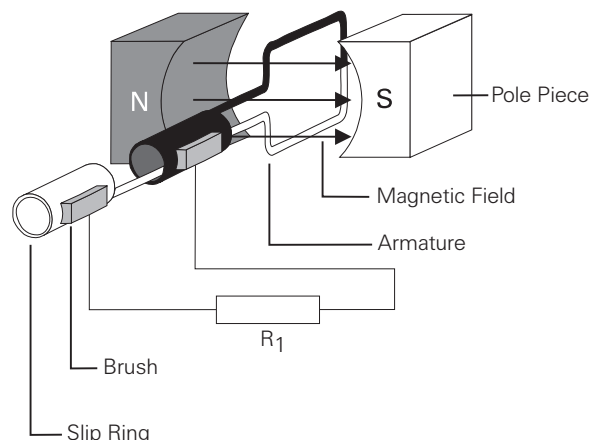

Basic Generator Operation

An armature rotates through the magnetic field. At an initial position of zero degrees, the armature conductors are moving parallel to the magnetic field and not cutting through any magnetic lines of flux. No voltage is induced.

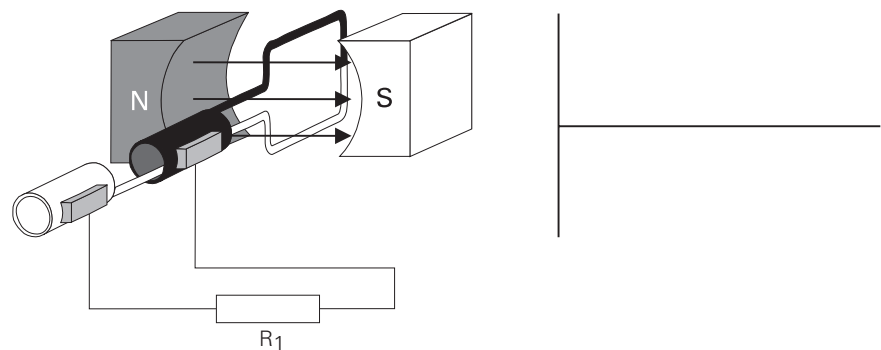

Generator Operation from Zero to 90 Degrees

The armature rotates from zero to 90 degrees. The conductors cut through more and more lines of flux, building up to a maximum induced voltage in the positive direction.

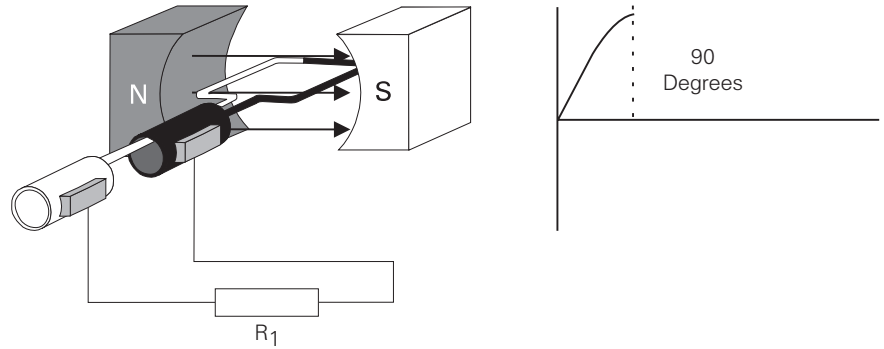

Generator Operation from 90 to 180 Degrees

The armature continues to rotate from 90 to 180 degrees, cutting less lines of flux. The induced voltage decreases from a maximum positive value to zero.

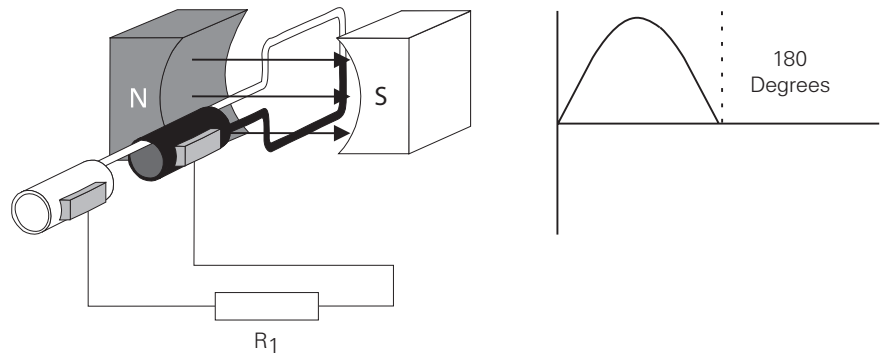

Generator Operation from 180 to 270 Degrees

The armature continues to rotate from 180 degrees to 270 degrees. The conductors cut more and more lines of flux, but in the opposite direction. Voltage is induced in the negative direction building up to a maximum at 270 degrees.

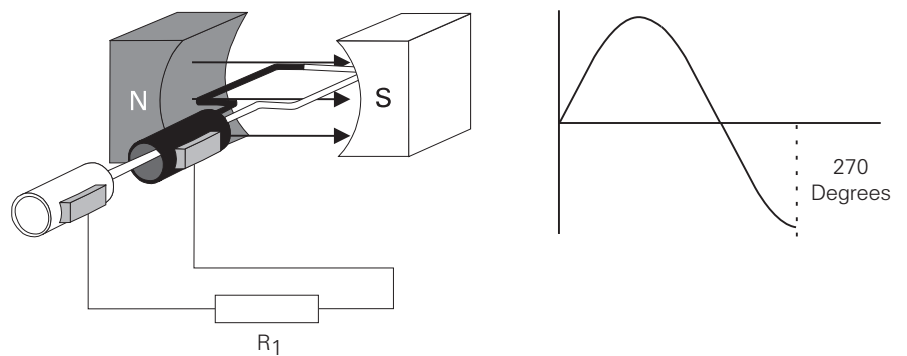

Generator Operation from 270 to 360 Degrees

The armature continues to rotate from 270 to 360 degrees. Induced voltage decreases from a maximum negative value to zero. This completes one cycle. The armature will continue to rotate at a constant speed. The cycle will continuously repeat as long as the armature rotates.

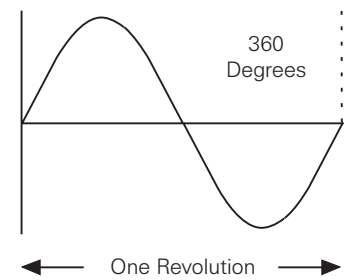
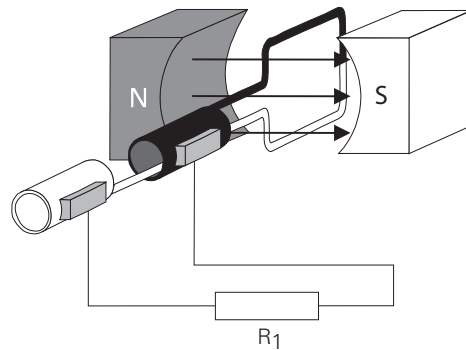

Frequency

The number of cycles per second made by voltage induced in the armature is the frequency of the generator. If the armature rotates at a speed of 60 revolutions per second, the generated voltage will be 60 cycles per second. The accepted term for cycles per second is hertz. The standard frequency in the United States is 60 hertz. The following illustration shows 15 cycles in 1/4 second which is equivalent to 60 cycles in one second.

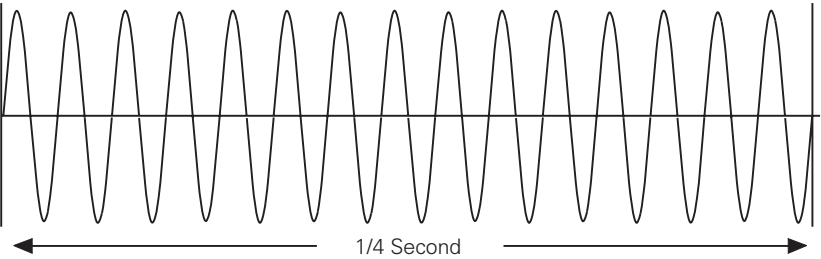

Four-Pole AC Generator

The frequency is the same as the number of rotations per second if the magnetic field is produced by only two poles. An increase in the number of poles, would cause an increase in the number of cycles completed in a revolution. A two-pole generator would complete one cycle per revolution and a four-pole generator would complete two cycles per revolution. An AC generator produces one cycle per revolution for each pair of poles.

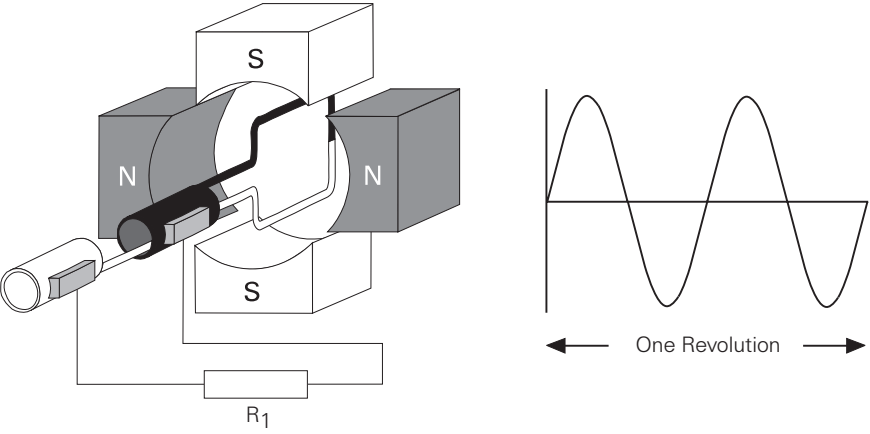

Voltage and Current

Peak Value

The sine wave illustrates how voltage and current in an AC circuit rises and falls with time. The peak value of a sine wave occurs twice each cycle, once at the positive maximum value and once at the negative maximum value.

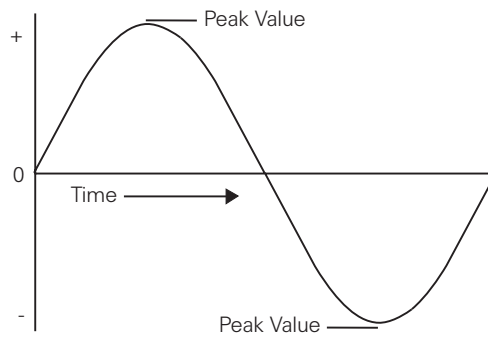

Peak-to-Peak Value

The value of the voltage or current between the peak positive and peak negative values is called the peak-to-peak value.

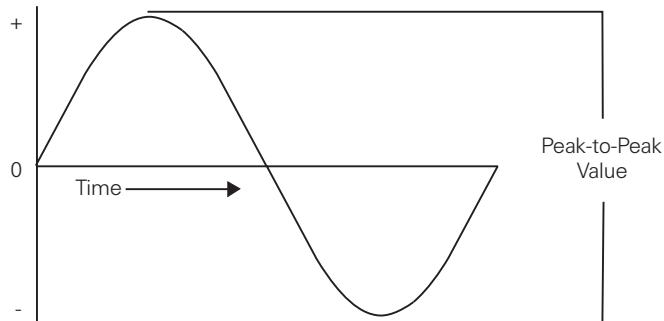

Instantaneous Value

The instantaneous value is the value at any one particular time. It can be in the range of anywhere from zero to the peak value.

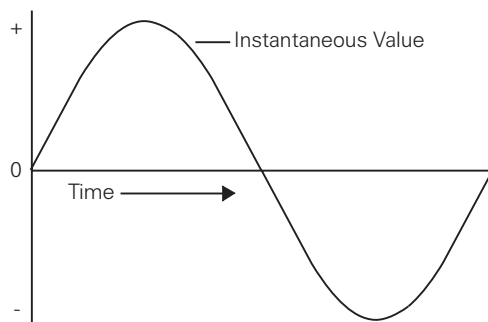

Calculating Instantaneous Voltage

The voltage waveform produced as the armature rotates through 360 degrees rotation is called a sine wave because instantaneous voltage is related to the trigonometric function called sine ($\sin \theta = \text{sine of the angle}$). The sine curve represents a graph of the following equation:

$$e = E_{\text{peak}} \times \sin \theta$$

Instantaneous voltage is equal to the peak voltage times the sine of the angle of the generator armature. The sine value is obtained from trigonometric tables. The following table reflects a few angles and their sine value.

Angle	Sin θ	Angle	Sin θ
30 Degrees	0.5	210 Degrees	-0.5
60 Degrees	0.866	240 Degrees	-0.866
90 Degrees	1	270 Degrees	-1
120 Degrees	0.866	300 Degrees	-0.866
150 Degrees	0.5	330 Degrees	-0.5
180 Degrees	0	360 Degrees	0

The following example illustrates instantaneous values at 90, 150, and 240 degrees. The peak voltage is equal to 100 volts. By substituting the sine at the instantaneous angle value, the instantaneous voltage can be calculated.

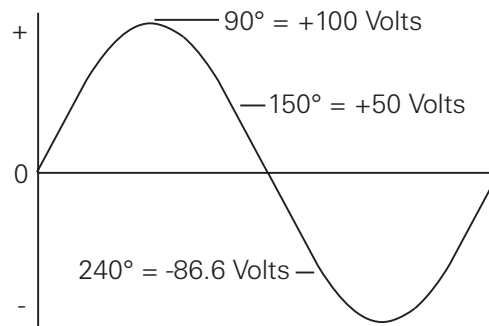

Any instantaneous value can be calculated. For example:

$$\begin{aligned} &240^\circ \\ e &= 100 \times -0.866 \\ e &= -86.6 \text{ volts} \end{aligned}$$

Effective Value of an AC Sine Wave

Alternating voltage and current are constantly changing values. A method of translating the varying values into an equivalent constant value is needed. The effective value of voltage and current is the common method of expressing the value of AC. This is also known as the RMS (root-mean-square) value. If the voltage in the average home is said to be 120 volts, this is the RMS value. The effective value figures out to be 0.707 times the peak value.

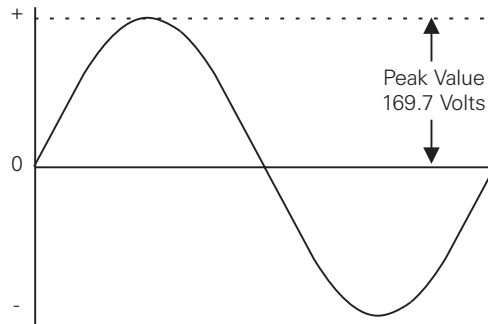

The effective value of AC is defined in terms of an equivalent heating effect when compared to DC. One RMS ampere of current flowing through a resistance will produce heat at the same rate as a DC ampere.

For purpose of circuit design, the peak value may also be needed. For example, insulation must be designed to withstand the peak value, not just the effective value. It may be that only the effective value is known. To calculate the peak value, multiply the effective value by 1.41. For example, if the effective value is 100 volts, the peak value is 141 volts.

Review 7

1. The graphic representation of AC voltage or current values over a period of time is a _____ .
2. Each phase of three phase AC power is offset by _____ degrees.
3. An AC generator produces _____ cycle per revolution for each pair of poles.
4. What is the instantaneous voltage at 240 degrees for a peak voltage of 150 volts?
5. What is the effective voltage for a peak voltage of 150 volts?

Inductance

The circuits studied to this point have been resistive. Resistance and voltage are not the only circuit properties that effect current flow, however. Inductance is the property of an electric circuit that opposes any change in electric current. Resistance opposes current flow, inductance opposes change in current flow. Inductance is designated by the letter "L". The unit of measurement for inductance is the henry (h).

Current Flow and Field Strength

Current flow produces a magnetic field in a conductor. The amount of current determines the strength of the magnetic field. As current flow increases, field strength increases, and as current flow decreases, field strength decreases.

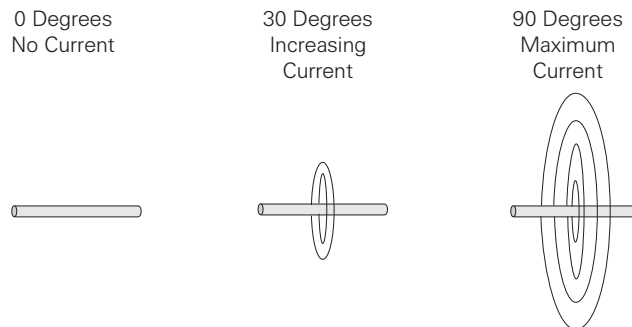

Any change in current causes a corresponding change in the magnetic field surrounding the conductor. Current is constant in DC, except when the circuit is turned on and off, or when there is a load change. Current is constantly changing in AC, so inductance is a continual factor. A change in the magnetic field surrounding the conductor induces a voltage in the conductor. This self-induced voltage opposes the change in current. This is known as counter emf. This opposition causes a delay in the time it takes current to attain its new steady value. If current increases, inductance tries to hold it down. If current decreases, inductance tries to hold it up. Inductance is somewhat like mechanical inertia which must be overcome to get a mechanical object moving or to stop a mechanical object from moving. A vehicle, for example, takes a few moments to accelerate to a desired speed, or decelerate to a stop.

Inductors

Inductance is usually indicated symbolically on an electrical drawing by one of two ways. A curled line or a filled rectangle can be used.

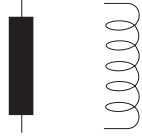

Inductors are coils of wire. They may be wrapped around a core. The inductance of a coil is determined by the number of turns in the coil, the spacing between the turns, the coil diameter, the core material, the number of layers of windings, the type of winding, and the shape of the coil. Examples of inductors are transformers, chokes, and motors.

Simple Inductive Circuit

In a resistive circuit, current change is considered instantaneous. If an inductor is used, the current does not change as quickly. In the following circuit, initially the switch is open and there is no current flow. When the switch is closed, current will rise rapidly at first, then more slowly as the maximum value is approached. For the purpose of explanation, a DC circuit is used.

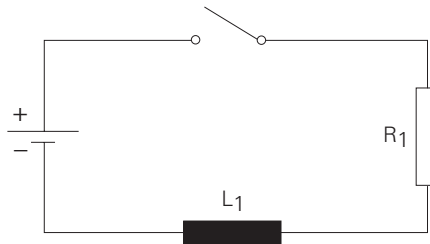

Inductive Time Constant

The time required for the current to rise to its maximum value is determined by the ratio of inductance (in henrys) to resistance (in ohms). This ratio is called the time constant of the inductive circuit. A time constant is the time (in seconds) required for the circuit current to rise to 63.2% of its maximum value. When the switch is closed in the previous circuit, current will begin to flow. During the first time constant current rises to 63.2% of its maximum value. During the second time constant, current rises to 63.2% of the remaining 36.8%, or a total of 86.4%. It takes about five time constants for current to reach its maximum value.

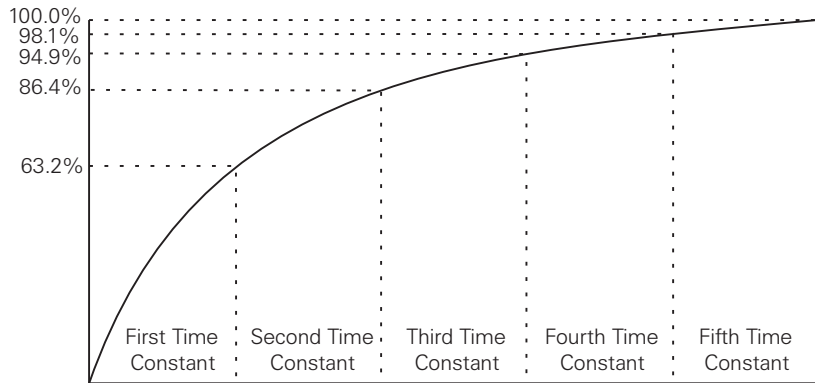

Similarly, when the switch is opened, it will take five time constants for current to reach zero. It can be seen that inductance is an important factor in AC circuits. If the frequency is 60 hertz, current will rise and fall from its peak value to zero 120 times a second.

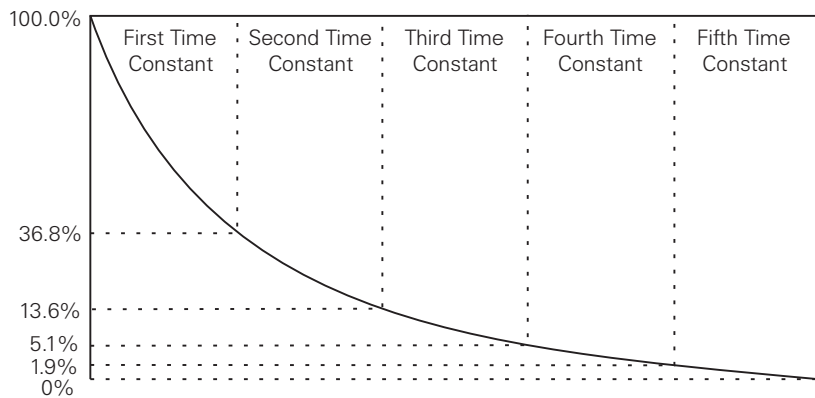

Calculating the Time Constant of an Inductive Circuit

The time constant is designated by the symbol “ τ .” To determine the time constant of an inductive circuit use one of the following formulas:

$$\tau \text{ (in seconds)} = \frac{L \text{ (henrys)}}{R \text{ (ohms)}}$$

$$\tau \text{ (in milliseconds)} = \frac{L \text{ (millihenrys)}}{R \text{ (ohms)}}$$

$$\tau \text{ (in microseconds)} = \frac{L \text{ (microhenrys)}}{R \text{ (ohms)}}$$

In the following illustration, L_1 is equal to 15 millihenrys and R_1 is equal to 5Ω . When the switch is closed, it will take 3 milliseconds for current to rise from zero to 63.2% of its maximum value.

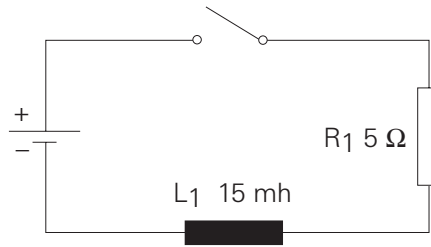

$$\tau = \frac{15 \text{ mh}}{5 \ \Omega}$$

$$\tau = 3 \text{ milliseconds}$$

Formula for Series Inductors

The same rules for calculating total resistance can be applied. In the following circuit, an AC generator is used to supply electrical power to four inductors. There will always be some amount of resistance and inductance in any circuit. The electrical wire used in the circuit and the inductors both have some resistance and inductance. Total inductance is calculated using the following formula:

$$L_t = L_1 + L_2 + L_3$$

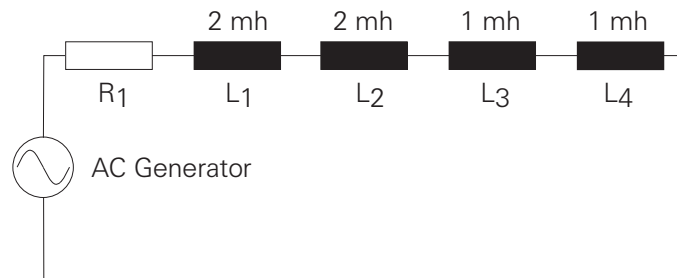

$$L_t = L_1 + L_2 + L_3 + L_4$$

$$L_t = 2 \text{ mh} + 2 \text{ mh} + 1 \text{ mh} + 1 \text{ mh}$$

$$L_t = 6 \text{ mh}$$

Formula for Parallel Inductors

In the following circuit, an AC generator is used to supply electrical power to three inductors. Total inductance is calculated using the following formula:

$$\frac{1}{L_t} = \frac{1}{L_1} + \frac{1}{L_2} + \frac{1}{L_3}$$

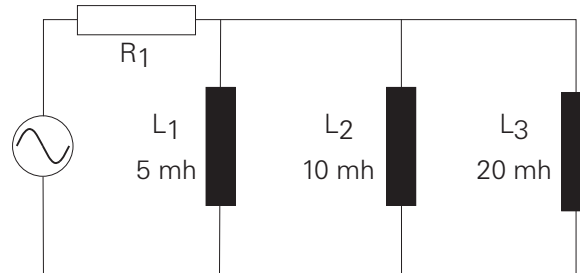

$$\frac{1}{L_t} = \frac{1}{5} + \frac{1}{10} + \frac{1}{20}$$

$$\frac{1}{L_t} = \frac{7}{20}$$

$$L_t = 2.86 \text{ mh}$$

Capacitance

Capacitance and Capacitors

Capacitance is a measure of a circuit's ability to store an electrical charge. A device manufactured to have a specific amount of capacitance is called a capacitor. A capacitor is made up of a pair of conductive plates separated by a thin layer of insulating material. Another name for the insulating material is dielectric material. When a voltage is applied to the plates, electrons are forced onto one plate. That plate has an excess of electrons while the other plate has a deficiency of electrons. The plate with an excess of electrons is negatively charged. The plate with a deficiency of electrons is positively charged.

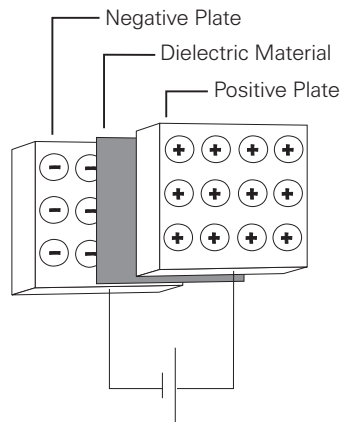

Direct current cannot flow through the dielectric material because it is an insulator; however it can be used to charge a capacitor. Capacitors have a capacity to hold a specific quantity of electrons. The capacitance of a capacitor depends on the area of the plates, the distance between the plates, and the material of the dielectric. The unit of measurement for capacitance is farads (F). Capacitors usually are rated in μF (microfarads), or pF (picofarads).

Capacitor Circuit Symbols

Capacitance is usually indicated symbolically on an electrical drawing by a combination of a straight line with a curved line, or two straight lines.

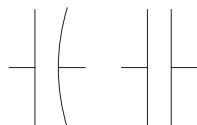

Simple Capacitive Circuit

In a resistive circuit, voltage change is considered instantaneous. If a capacitor is used, the voltage across the capacitor does not change as quickly. In the following circuit, initially the switch is open and no voltage is applied to the capacitor. When the switch is closed, voltage across the capacitor will rise rapidly at first, then more slowly as the maximum value is approached. For the purpose of explanation, a DC circuit is used.

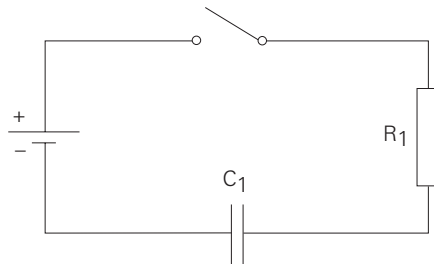

Capacitive Time Constant

The time required for voltage to rise to its maximum value in a circuit containing capacitance is determined by the product of capacitance, in farads, times resistance, in ohms. This product is the time constant of a capacitive circuit. The time constant gives the time in seconds required for voltage across the capacitor to reach 63.2% of its maximum value. When the switch is closed in the previous circuit, voltage will be applied. During the first time constant, voltage will rise to 63.2% of its maximum value. During the second time constant, voltage will rise to 63.2% of the remaining 36.8%, or a total of 86.4%. It takes about five time constants for voltage across the capacitor to reach its maximum value.

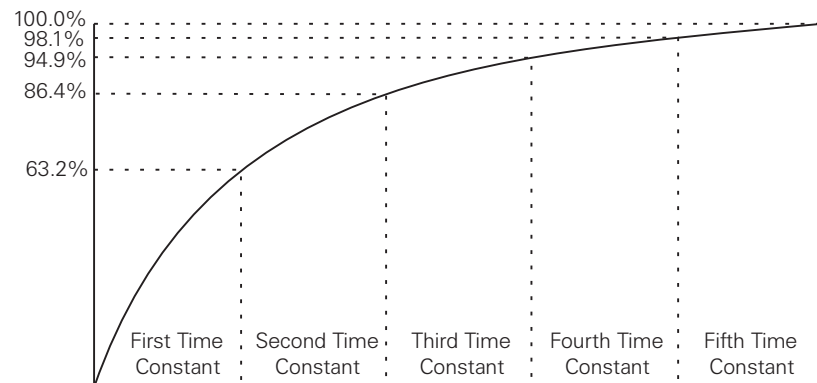

Similarly, during this same time, it will take five time constants for current through the resistor to reach zero.

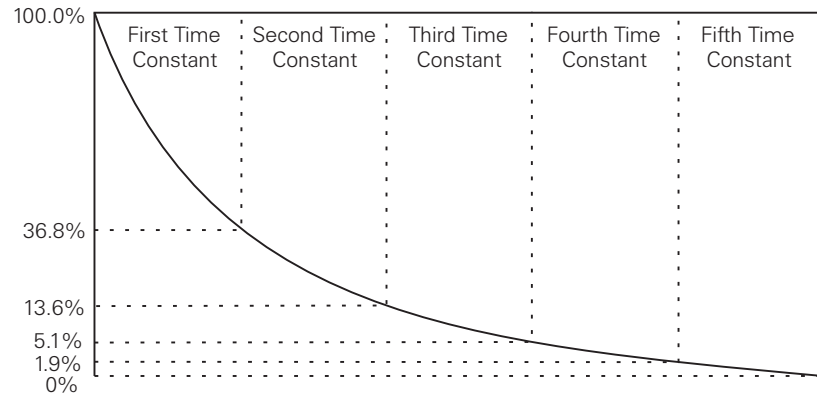

Calculating the Time Constant of a Capacitive Circuit

To determine the time constant of a capacitive circuit, use one of the following formulas:

$$\tau \text{ (in seconds)} = R \text{ (megohms)} \times C \text{ (microfarads)}$$

$$\tau \text{ (in microseconds)} = R \text{ (megohms)} \times C \text{ (picofarads)}$$

$$\tau \text{ (in microseconds)} = R \text{ (ohms)} \times C \text{ (microfarads)}$$

In the following illustration, C_1 is equal to $2 \mu\text{F}$, and R_1 is equal to 10Ω . When the switch is closed, it will take 20 microseconds for voltage across the capacitor to rise from zero to 63.2% of its maximum value. It will take five time constants, 100 microseconds for this voltage to rise to its maximum value.

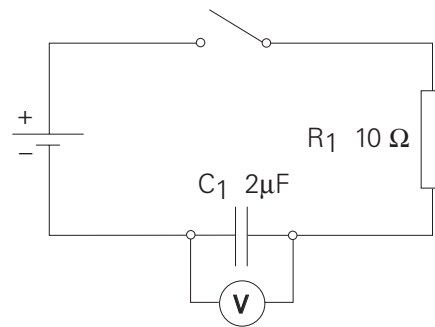

$$\tau = RC$$

$$\tau = 2\mu\text{F} \times 10 \Omega$$

$$\tau = 20 \text{ microseconds}$$

Formula for Series Capacitors

Connecting capacitors in series decreases total capacitance. The effect is like increasing the space between the plates. The formula for series capacitors is similar to the formula for parallel resistors. In the following circuit, an AC generator supplies electrical power to three capacitors. Total capacitance is calculated using the following formula:

$$\frac{1}{C_t} = \frac{1}{C_1} + \frac{1}{C_2} + \frac{1}{C_3}$$

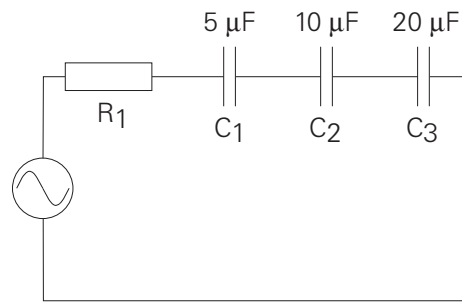

$$\frac{1}{C_t} = \frac{1}{5} + \frac{1}{10} + \frac{1}{20}$$

$$\frac{1}{C_t} = \frac{7}{20}$$

$$C_t = 2.86 \mu\text{F}$$

Formula for Parallel Capacitors

In the following circuit, an AC generator is used to supply electrical power to three capacitors. Total capacitance is calculated using the following formula:

$$C_t = C_1 + C_2 + C_3$$

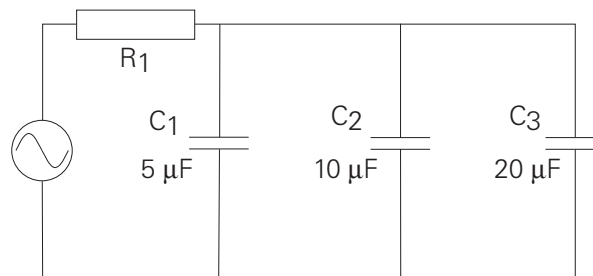

$$C_t = 5 \mu\text{F} + 10 \mu\text{F} + 20 \mu\text{F}$$

$$C_t = 35 \mu\text{F}$$

Review 8

1. The total inductance for this circuit is _____ .

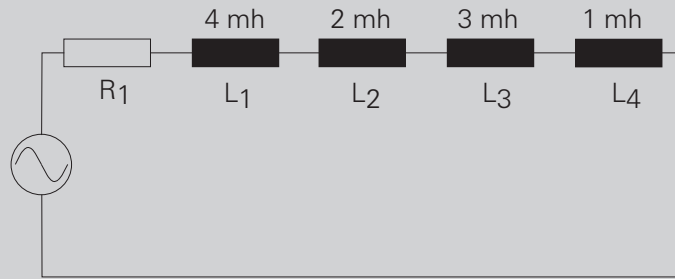

2. The total inductance for this circuit is _____ .

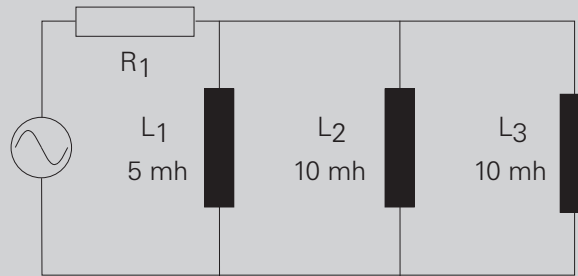

3. The total capacitance for this circuit is _____ .

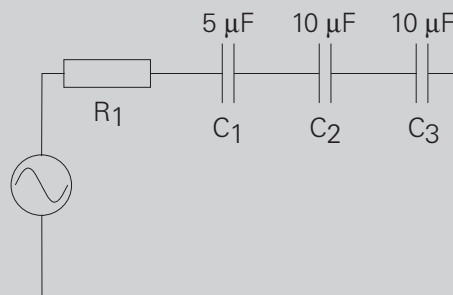

4. The total capacitance for this circuit is _____ .

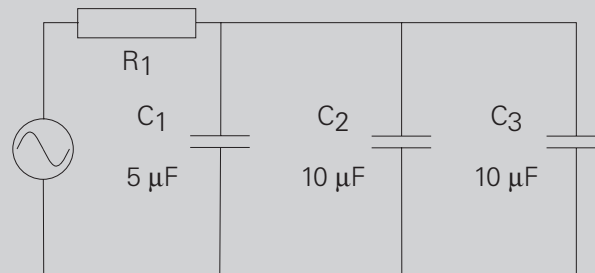

Inductive and Capacitive Reactance

In a purely resistive AC circuit, opposition to current flow is called resistance. In an AC circuit containing only inductance, capacitance, or both, opposition to current flow is called reactance. Total opposition to current flow in an AC circuit that contains both reactance and resistance is called impedance, designated by the symbol "Z." Reactance and impedance are expressed in ohms.

Inductive Reactance

Inductance only affects current flow when the current is changing. Inductance produces a self-induced voltage (counter emf) that opposes changes in current. In an AC circuit, current is changing constantly. Inductance in an AC circuit, therefore, causes a continual opposition. This opposition to current flow is called inductive reactance and is designated by the symbol X_L .

Inductive reactance is dependent on the amount of inductance and frequency. If frequency is low, current has more time to reach a higher value before the polarity of the sine wave reverses. If frequency is high, current has less time to reach a higher value. In the following illustration, voltage remains constant. Current rises to a higher value at a lower frequency than a higher frequency.

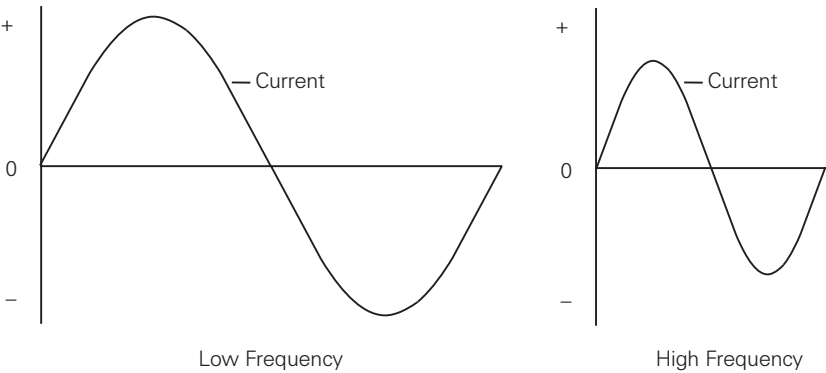

The formula for inductive reactance is:

$$X_L = 2\pi fL$$
$$X_L = 2 \times 3.14 \times \text{frequency} \times \text{inductance}$$

In a 60 hertz, 10 volt circuit containing a 10 mh inductor, the inductive reactance would be:

$$X_L = 2\pi fL$$

$$X_L = 2 \times 3.14 \times 60 \times 0.10$$

$$X_L = 3.768 \Omega$$

Once inductive reactance is known, Ohm's Law can be used to calculate reactive current.

$$I = \frac{E}{Z}$$

$$I = \frac{10}{3.768}$$

$$I = 2.65 \text{ Amps}$$

Phase Relationship between Current and Voltage in an Inductive Circuit

Current does not rise at the same time as the source voltage in an inductive circuit. Current is delayed depending on the amount of inductance. In a purely resistive circuit, current and voltage rise and fall at the same time. They are said to be "in phase." In this circuit there is no inductance. Resistance and impedance are the same.

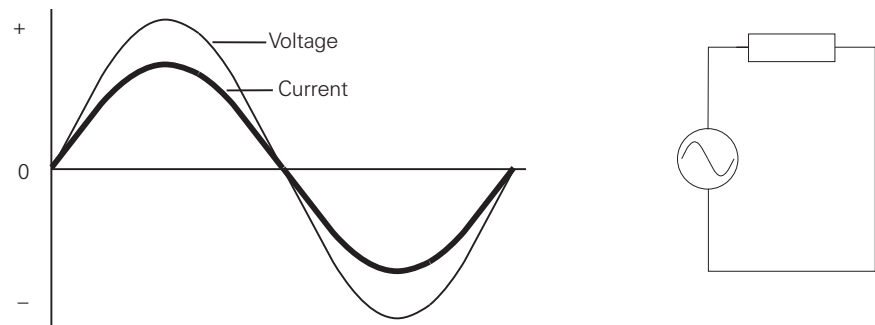

In a purely inductive circuit, current lags behind voltage by 90 degrees. Current and voltage are said to be "out of phase." In this circuit, impedance and inductive reactance are the same.

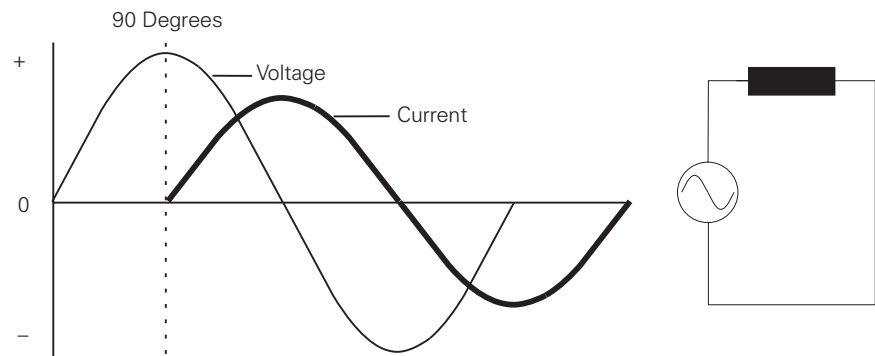

All inductive circuits have some amount of resistance. AC current will lag somewhere between a purely resistive circuit, and a purely inductive circuit. The exact amount of lag depends on the ratio of resistance and inductive reactance. The more resistive a circuit is, the closer it is to being in phase. The more inductive a circuit is, the more out of phase it is. In the following illustration, resistance and inductive reactance are equal. Current lags voltage by 45 degrees.

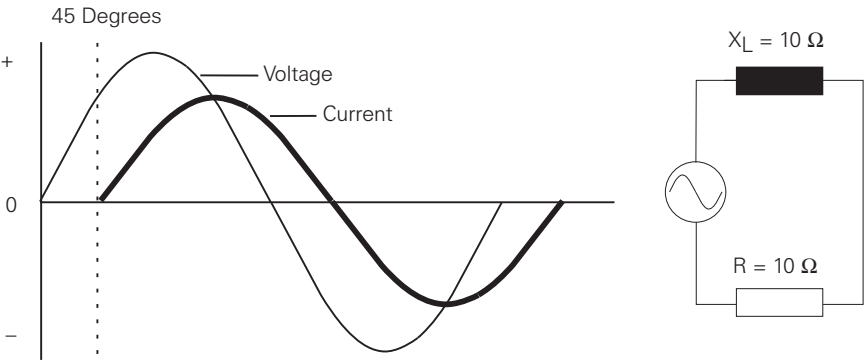

Calculating Impedance in an Inductive Circuit

When working with a circuit containing elements of inductance, capacitance, and resistance, impedance must be calculated. Because electrical concepts deal with trigonometric functions, this is not a simple matter of subtraction and addition. The following formula is used to calculate impedance in an inductive circuit:

$$Z = \sqrt{R^2 + X_L^2}$$

In the circuit illustrated above, resistance and inductive reactance are each 10 ohms. Impedance is 14.1421 ohms. A simple application of Ohm’s Law can be used to find total circuit current.

$$Z = \sqrt{10^2 + 10^2}$$

$$Z = \sqrt{200}$$

$$Z = 14.1421 \Omega$$

Vectors

Another way to represent this is with a vector. A vector is a graphic representation of a quantity that has direction and magnitude. A vector on a map might indicate that one city is 50 miles southwest from another. The magnitude is 50 miles and the direction is southwest. Vectors are also used to show electrical relationships. As mentioned earlier, impedance (Z) is the total opposition to current flow in an AC circuit containing reactance, inductance, and capacitance.

The following vector illustrates the relationship between reactance and inductive reactance of a circuit containing equal values of each. The angle between the vectors is the phase angle represented by the symbol θ . When inductive reactance is equal to resistance the resultant angle is 45 degrees. It is this angle that determines how much current will lag voltage.

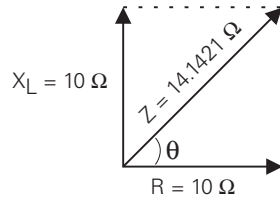

Capacitive Reactance

Capacitance also opposes AC current flow. Capacitive reactance is designated by the symbol X_C . The larger the capacitor, the smaller the capacitive reactance. Current flow in a capacitive AC circuit is also dependent on frequency. The following formula is used to calculate capacitive reactance.

$$X_C = \frac{1}{2\pi fC}$$

Capacitive reactance is equal to 1 divided by 2 times pi, times the frequency, times the capacitance. The capacitive reactance for a 60 hertz circuit with a 10 microfarad capacitor is:

$$X_C = \frac{1}{2\pi fC}$$

$$X_C = \frac{1}{2 \times 3.14 \times 60 \times 0.000010}$$

$$X_C = 265.39 \Omega$$

Once capacitive reactance is known, Ohm's Law can be used to calculate reactive current.

$$I = \frac{E}{Z}$$

$$I = \frac{10}{265.39}$$

$$I = 0.0376 \text{ Amps}$$

Phase Relationship between Current and Voltage

The phase relationship between current and voltage are opposite to the phase relationship of an inductive circuit. In a purely capacitive circuit, current leads voltage by 90 degrees.

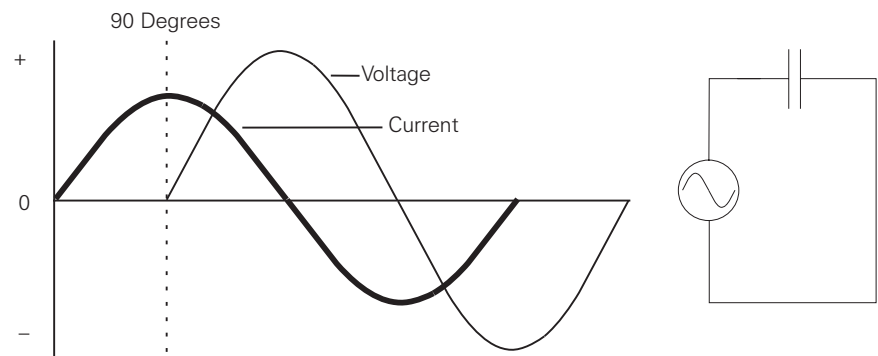

All capacitive circuits have some amount of resistance. AC current will lead somewhere between a purely resistive circuit and a purely capacitive circuit. The exact amount of lead depends on the ratio of resistance and capacitive reactance. The more resistive a circuit is, the closer it is to being in phase. The more capacitive a circuit is, the more out of phase it is. In the following illustration, resistance and capacitive reactance are equal. Current leads voltage by 45 degrees.

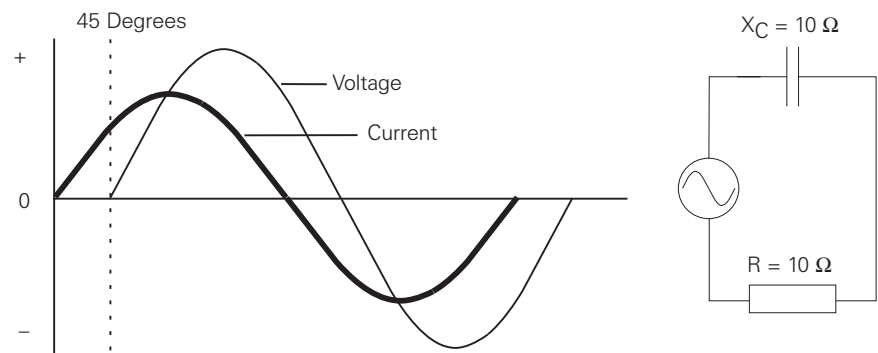

Calculating Impedance in a Capacitive Circuit

The following formula is used to calculate impedance in a capacitive circuit:

$$Z = \sqrt{R^2 + X_C^2}$$

In the circuit illustrated above, resistance and capacitive reactance are each 10 ohms. Impedance is 14.1421 ohms.

$$Z = \sqrt{10^2 + 10^2}$$

$$Z = \sqrt{200}$$

$$Z = 14.1421 \Omega$$

The following vector illustrates the relationship between resistance and capacitive reactance of a circuit containing equal values of each. The angle between the vectors is the phase angle represented by the symbol θ . When capacitive reactance is equal to resistance the resultant angle is -45 degrees. It is this angle that determines how much current will lead voltage.

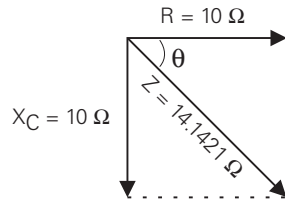

Review 9

1. In a circuit containing inductance, capacitance, or both, opposition to current flow is called _____ .
2. Total opposition to current flow in a circuit that contains both reactance and resistance is called _____ .
3. In a 50 hertz circuit, containing a 10 mh inductor, the inductive reactance is _____ ohms.
4. In a purely inductive circuit, _____
 - a. current and voltage are in phase
 - b. current leads voltage by 90 degrees
 - c. current lags voltage by 90 degrees
5. In a purely capacitive circuit, _____
 - a. current and voltage are in phase
 - b. current leads voltage by 90 degrees
 - c. current lags voltage by 90 degrees
6. In a 50 hertz circuit, containing a 10 microfarad capacitor, the capacitive reactance is _____ ohms.
7. In a circuit with 5Ω resistance, and 10Ω inductive reactance, impedance is _____ ohms.
8. In a circuit with 5Ω resistance, and 4Ω capacitive reactance, impedance is _____ ohms.

Series R-L-C Circuit

Circuits often contain elements of resistance, inductance, and capacitance. In an inductive AC circuit, current lags voltage by 90 degrees. In a AC capacitive circuit, current leads voltage by 90 degrees. It can be seen that inductance and capacitance are 180 degrees apart. Since they are 180 degrees apart, one element will cancel out all or part of the other element.

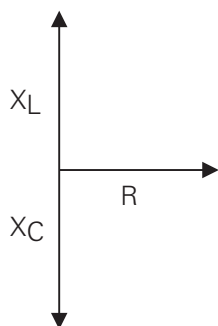

An AC circuit is:

- Resistive if X_L and X_C are equal
- Inductive if X_L is greater than X_C
- Capacitive if X_C is greater than X_L

Calculating Total Impedance in a Series R-L-C Circuit

The following formula is used to calculate total impedance of a circuit containing resistance, capacitance, and inductance:

$$Z = \sqrt{R^2 + (X_L - X_C)^2}$$

In the case where inductive reactance is greater than capacitive reactance, subtracting X_C from X_L results in a positive number. The positive phase angle is an indicator that the net circuit reactance is inductive, and current lags voltage.

In the case where capacitive reactance is greater than inductive reactance, subtracting X_C from X_L results in a negative number. The negative phase angle is an indicator that the net circuit reactance is capacitive and current leads voltage. In either case, the value squared will result in positive number.

Calculating Reactance and Impedance in a Series R-L-C Circuit

In the following 120 volt, 60 hertz circuit, resistance is 1000 Ω , inductance is 5 mh, and capacitance is 2 μ F. To calculate total impedance, first calculate the value of X_L and X_C , then impedance can be calculated.

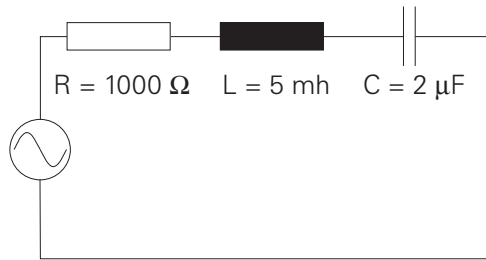

$$\begin{aligned}X_L &= 2\pi fL \\X_L &= 6.28 \times 60 \times 0.005 \\X_L &= 1.884 \Omega\end{aligned}$$

$$\begin{aligned}X_C &= \frac{1}{2\pi fC} \\X_C &= \frac{1}{6.28 \times 60 \times 0.000002}\end{aligned}$$

$$X_C = 1,327 \Omega$$

$$\begin{aligned}Z &= \sqrt{R^2 + (X_L - X_C)^2} \\Z &= \sqrt{1000^2 + (1.884 - 1,327)^2} \\Z &= \sqrt{1,000,000 + (-1,325.116)^2} \\Z &= \sqrt{1,000,000 + 1,755,932.41} \\Z &= \sqrt{2,755,932.41} \\Z &= 1,660.1 \Omega\end{aligned}$$

Calculating Circuit Current in a Series R-L-C Circuit

Ohm's Law can be applied to calculate total circuit current.

$$\begin{aligned}I &= \frac{E}{Z} \\I &= \frac{120}{1,660.1} \\I &= 0.072 \text{ Amps}\end{aligned}$$

Parallel R-L-C Circuit

Calculating Impedance in a Parallel R-L-C Circuit

Total impedance (Z_t) can be calculated in a parallel R-L-C circuit if values of resistance and reactance are known. One method of calculating impedance involves first calculating total current, then using the following formula:

$$Z_t = \frac{E_t}{I_t}$$

Total current is the vector sum of current flowing through the resistance plus, the difference between inductive current and capacitive current. This is expressed in the following formula:

$$I_t = \sqrt{I_R^2 + (I_C - I_L)^2}$$

In the following 120 volt, 60 hertz circuit, capacitive reactance has been calculated to be 25Ω and inductive reactance 50Ω . Resistance is 1000Ω . A simple application of Ohm's Law will find the branch currents. Remember, voltage is constant throughout a parallel circuit.

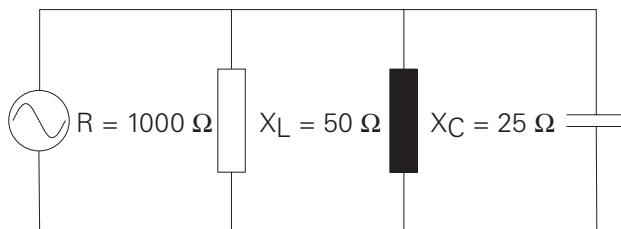

$$I_R = \frac{E}{R}$$

$$I_R = \frac{120}{1000}$$

$$I_R = 0.12 \text{ Amps}$$

$$I_L = \frac{E}{X_L}$$

$$I_L = \frac{120}{50}$$

$$I_L = 2.4 \text{ Amps}$$

$$I_C = \frac{E}{X_C}$$

$$I_C = \frac{120}{25}$$

$$I_C = 4.8 \text{ Amps}$$

Once the branch currents are known, total current can be calculated.

$$I_t = \sqrt{I_R^2 + (I_C - I_L)^2}$$

$$I_t = \sqrt{0.12^2 + (4.8 - 2.4)^2}$$

$$I_t = \sqrt{0.0144 + 5.76}$$

$$I_t = \sqrt{5.7744}$$

$$I_t = 2.4 \text{ Amps}$$

Impedance is now found with an application of Ohm's Law.

$$Z_t = \frac{E_t}{I_t}$$

$$Z_t = \frac{120}{2.4}$$

$$Z_t = 50 \Omega$$

Power and Power Factor in an AC Circuit

Power consumed by a resistor is dissipated in heat and not returned to the source. This is true power. True power is the rate at which energy is used.

Current in an AC circuit rises to peak values and diminishes to zero many times a second. The energy stored in the magnetic field of an inductor, or plates of a capacitor, is returned to the source when current changes direction.

Although reactive components do not consume energy, they do increase the amount of energy that must be generated to do the same amount of work. The rate at which this non-working energy must be generated is called reactive power.

Power in an AC circuit is the vector sum of true power and reactive power. This is called apparent power. True power is equal to apparent power in a purely resistive circuit because voltage and current are in phase. Voltage and current are also in phase in a circuit containing equal values of inductive reactance and capacitive reactance. If voltage and current are 90 degrees out of phase, as would be in a purely capacitive or purely inductive circuit, the average value of true power is equal to zero. There are high positive and negative peak values of power, but when added together the result is zero.

True Power and Apparent Power Formulas

The formula for apparent power is:

$$P = EI$$

Apparent power is measured in volt-amps (VA).

True power is calculated from another trigonometric function, the cosine of the phase angle ($\cos \theta$). The formula for true power is:

$$P = EI \cos \theta$$

True power is measured in watts.

In a purely resistive circuit, current and voltage are in phase. There is a zero degree angle displacement between current and voltage. The cosine of zero is one. Multiplying a value by one does not change the value. In a purely resistive circuit the cosine of the angle is ignored.

In a purely reactive circuit, either inductive or capacitive, current and voltage are 90 degrees out of phase. The cosine of 90 degrees is zero. Multiplying a value times zero results in a zero product. No power is consumed in a purely reactive circuit.

Calculating Apparent Power in a simple R-L-C Circuit

In the following 120 volt circuit, current is equal to 84.9 milliamps. Inductive reactance is 100Ω and capacitive reactance is 1100Ω . The phase angle is -45 degrees. By referring to a trigonometric table, the cosine of -45 degrees is found to be $.7071$.

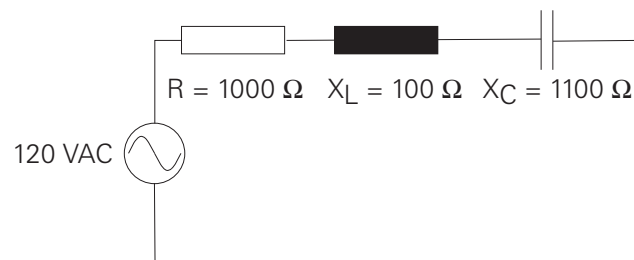

The apparent power consumed by the circuit is:

$$P = EI$$

$$P = 120 \times 0.0849$$

$$P = 10.2 \text{ VA}$$

The true power consumed by the circuit is:

$$P = EI \cos \theta$$

$$P = 120 \times 0.0849 \times 0.7071$$

$$P = 7.2 \text{ Watts}$$

Another formula for true power is:

$$P = I^2R$$

$$P = 0.0849^2 \times 1000$$

$$P = 7.2 \text{ Watts}$$

Power Factor

Power factor is the ratio of true power to apparent power in an AC circuit. Power factor is expressed in the following formula:

$$PF = \frac{\text{True Power}}{\text{Apparent Power}}$$

Power factor can also be expressed using the formulas for true power and apparent power. The value of EI cancels out because it is the same in the numerator and denominator. Power factor is the cosine of the angle.

$$PF = \frac{EI \cos \theta}{EI}$$

$$PF = \cos \theta$$

In a purely resistive circuit, where current and voltage are in phase, there is no angle of displacement between current and voltage. The cosine of a zero degree angle is one. The power factor is one. This means that all energy delivered by the source is consumed by the circuit and dissipated in the form of heat.

In a purely reactive circuit, voltage and current are 90 degrees apart. The cosine of a 90 degree angle is zero. The power factor is zero. This means the circuit returns all energy it receives from the source to the source.

In a circuit where reactance and resistance are equal, voltage and current are displaced by 45 degrees. The cosine of a 45 degree angle is .7071. The power factor is .7071. This means the circuit uses approximately 70% of the energy supplied by the source and returns approximately 30%.

Review 10

1. An AC circuit is _____ if inductive reactance and capacitive reactance are equal.
2. A series AC circuit is _____ if there is more inductive reactance than capacitive reactance.
3. A series AC circuit is _____ if there is more capacitive reactance than inductive reactance.
4. In a 120 VAC, 60 hertz series circuit, with $1000\ \Omega$ of resistance, 10 mh of inductance and $4\ \mu\text{F}$ of capacitance, impedance is _____ Ω and current is _____ amps.
5. In the illustrated circuit,

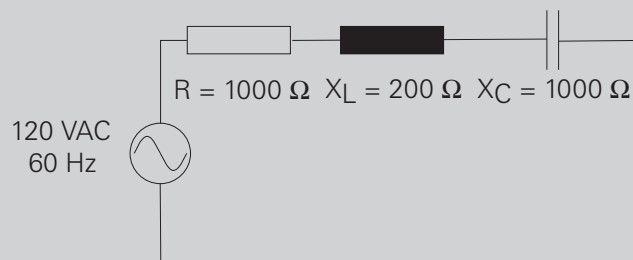

- I_t is _____ amps, and impedance is _____ Ω .
6. True power is measured in _____ .
 7. A circuit with 0.2 amps flowing through $100\ \Omega$ of resistance, is consuming _____ watts.

Transformers

Mutual Induction

Transformers are electromagnetic devices that transfer electrical energy from one circuit to another by mutual induction. Mutual induction is the coupling of inductances by their mutual magnetic fields. In a single-phase transformer there are two coils, a primary and a secondary coil. The following circuit illustrates mutual induction. The AC generator provides electrical power to the primary coil. The magnetic field produced by the primary induces a voltage into the secondary coil, which supplies power to a load.

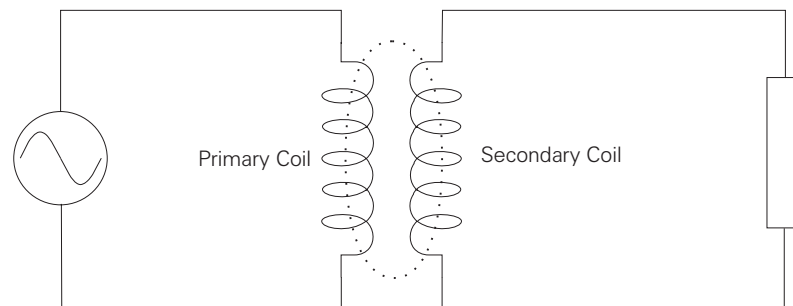

Transformers are used to step a voltage up to a higher level, or down to a lower level. Transformers are used extensively in power distribution systems, allowing power companies to transfer electrical energy many miles. Power generators typically generate high voltages. This voltage varies, depending on the generator, but a typical voltage might be 15 KV. The voltage is stepped up through a transformer to higher levels for transmission to substations. Typical voltages range from 115 KV to 765 KV. The electrical power is received at substation transformers many miles away where it is stepped down. Typical voltage might be 34 KV or 69 KV. From here, electrical power is fed to a distribution substation. It can also be fed directly to factory locations. If the power is fed to a factory, transformers at the factory site reduce the voltage to usable levels. The power fed to a distribution substation is reduced by transformers at the substation for factory and home use.

Coefficient of Coupling

Mutual inductance between two coils depends on their flux linkage. Maximum coupling occurs when all the lines of flux from the primary coil cut through the secondary winding. The amount of coupling which takes place is referred to as coefficient of coupling. To maximize coefficient of coupling, both coils are often wound on an iron core which is used to provide a path for the lines of flux. The following discussion of step-up and step-down transformers applies to transformers with an iron core.

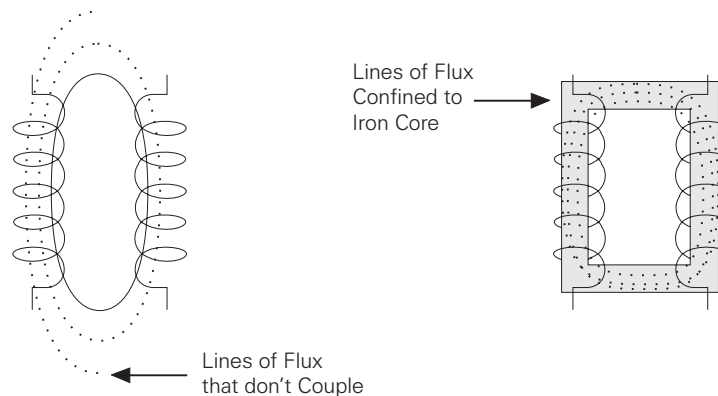

Voltage, Current, and the Number of Turns in a Coil

There is a direct relationship between voltage, impedance, current, and the number of coil turns in a transformer. This relationship can be used to find either primary or secondary voltage, current, and the number of turns in each coil. It is the number of turns which determine if a transformer is a step up or step down transformer. The following "rules-of-thumb" apply to transformers:

- If the primary coil has fewer turns than the secondary coil, it is a step-up transformer.
- If the primary coil has more turns than the secondary coil, it is a step-down transformer.

When the number of turns on the primary and secondary coils of a transformer are equal, input voltage, impedance, and current are equal to output voltage, impedance, and current.

Step-Up Transformer

A step-up transformer is used when it is desirable to step voltage up in value. The following circuit illustrates a step-up transformer. The primary coil has fewer turns than the secondary coil. The number of turns in a transformer is given as a ratio. When the primary has fewer turns than the secondary, voltage and impedance are stepped up. In the circuit illustrated, voltage is stepped up from 120 VAC to 240 VAC. Because impedance is also stepped up, current is stepped down from 10 amps to 5 amps.

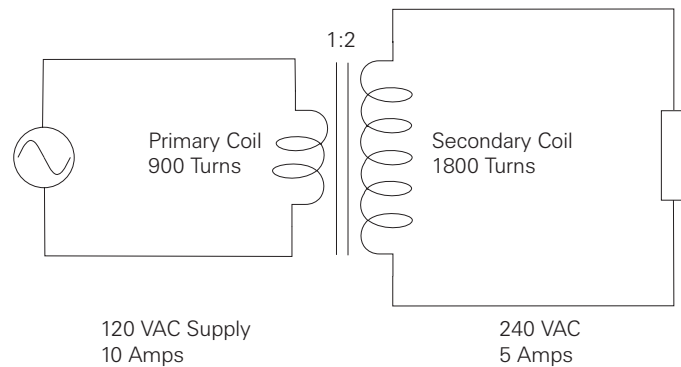

Step-Down Transformer

A step-down transformer is used when it is desirable to step voltage down in value. The following circuit illustrates a step-down transformer. The primary coil has more turns than the secondary coil. The step-down ratio is 2:1. voltage and impedance are stepped down, current is stepped up.

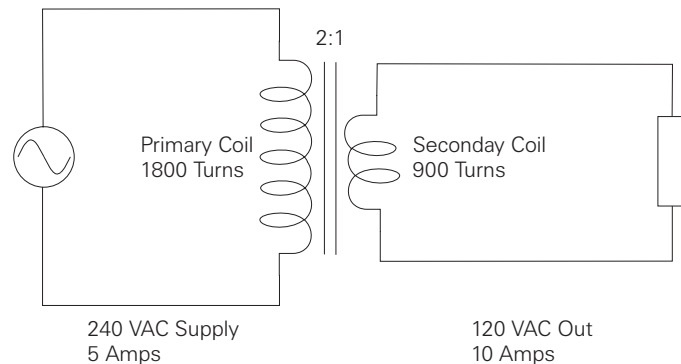

Single-Phase Transformer

120 or 240 VAC single-phase transformers are used to supply lighting, receptacle, and small appliance loads. A transformer with a 240 VAC secondary can be used to supply 240 VAC to larger appliances such as stoves, air conditioners and heaters. A 240 VAC secondary can be tapped in the center to provide two sources of 120 VAC power.

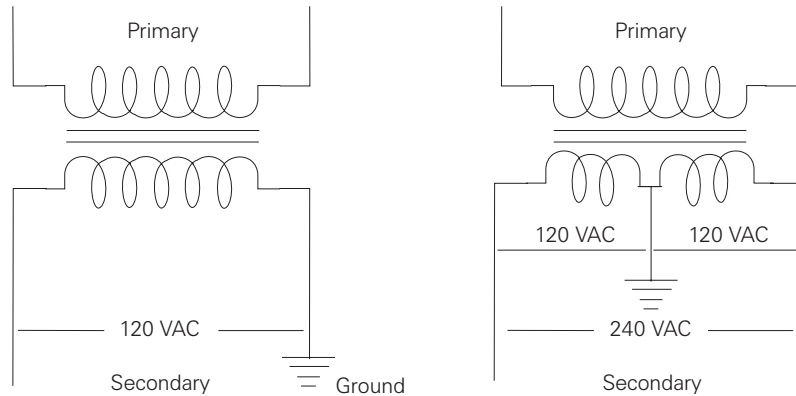

Formulas for Calculating the Number of Primary and Secondary Turns of a Transformer

There are a number of useful formulas for calculating, voltage, current, and the number of turns between the primary and secondary of a transformer. These formulas can be used with either step-up or step-down transformers. The following legend applies to the transformer formulas:

E_S	=	secondary voltage
E_P	=	primary voltage
I_S	=	secondary current
I_P	=	primary current
N_S	=	turns in the secondary coil
N_P	=	turns in the primary coil

To find voltage:

$$E_S = \frac{E_P \times I_P}{I_S} \quad E_P = \frac{E_S \times I_S}{I_P}$$

To find current:

$$I_S = \frac{E_P \times I_P}{E_S} \quad I_P = \frac{E_S \times I_S}{E_P}$$

To find the number of coil turns:

$$N_S = \frac{E_S \times N_P}{E_P} \quad N_P = \frac{E_P \times N_S}{E_S}$$

Using the values for the step-down transformer in the example of the previous page, the secondary voltage can be verified.

$$E_S = \frac{E_P \times I_P}{I_S}$$

$$E_S = \frac{240 \text{ Volts} \times 5 \text{ Amps}}{10 \text{ Amps}}$$

$$E_S = \frac{1200}{10}$$

$$E_S = 120 \text{ Volts}$$

Transformer Ratings

Transformers are rated in kVA (kilovolt-amperes). This rating is used rather than watts because loads are not purely resistive. Only resistive loads are measured in watts. The kVA rating determines the current a transformer can deliver to its load without overheating. Given volts and amps, kVA can be calculated. Given kVA and volts, amps can be calculated.

$$\text{kVA} = \frac{\text{Volts} \times \text{Amps}}{1000}$$

$$\text{Amps} = \frac{\text{kVA} \times 1000}{\text{Volts}}$$

Using the illustrated step-down transformer, the kVA rating can be calculated. The kVA rating of a transformer is the same for both the primary and the secondary.

$$\text{Primary kVA} = \frac{240 \times 5}{1000}$$

$$\text{Primary kVA} = 1.2 \text{ kVA}$$

$$\text{Secondary kVA} = \frac{120 \times 10}{1000}$$

$$\text{Secondary kVA} = 1.2 \text{ kVA}$$

Transformer Losses

Most of the electrical energy provided to the primary of a transformer is transferred to the secondary. Some energy, however, is lost in heat in the wiring or the core. Some losses in the core can be reduced by building the core of a number of flat sections called laminations.

Three-Phase Transformers

Delta Connections

Three-phase transformers are used when three-phase power is required for larger loads such as industrial motors. There are two basic three-phase transformer connections, delta and wye. Delta transformers are used where the distance from the supply to the load is short. A delta is like three single-phase transformers connected together. The secondary of a delta transformer is illustrated below. For simplicity, only the secondary of a three-phase transformer is shown. The voltages shown on the illustration are secondary voltages available to the load. Delta transformers are schematically drawn in a triangle. The voltages across each winding of the delta triangle represents one phase of a three phase system. The voltage is always the same between any two wires. A single phase (L1 to L2) can be used to supply single phase loads. All three phases are used to supply three phase loads.

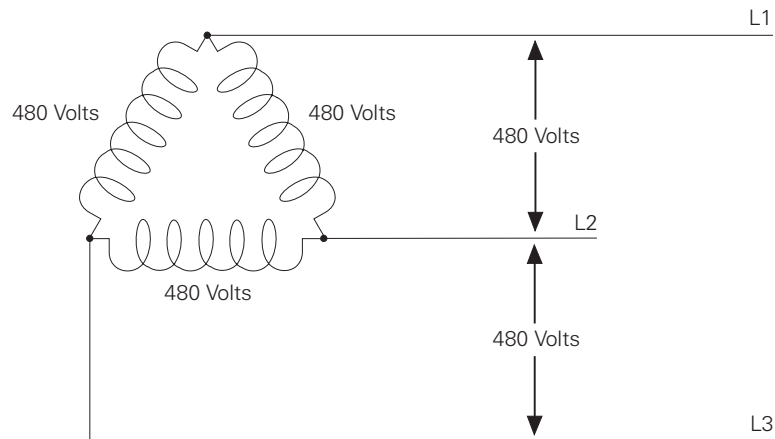

L1 to L2 = 480 volts
L2 to L3 = 480 volts
L1 to L3 = 480 volts

Balanced Delta Current

When current is the same in all three coils, it is said to be balanced. In each phase, current has two paths to follow. For example, current flowing from L1 to the connection point at the top of the delta can flow down through one coil to L2, and down through another coil to L3. When current is balanced, coil current is 58% of the line current measured on each phase. If the line current is 50 amps on each phase, coil current would be 29 amps.

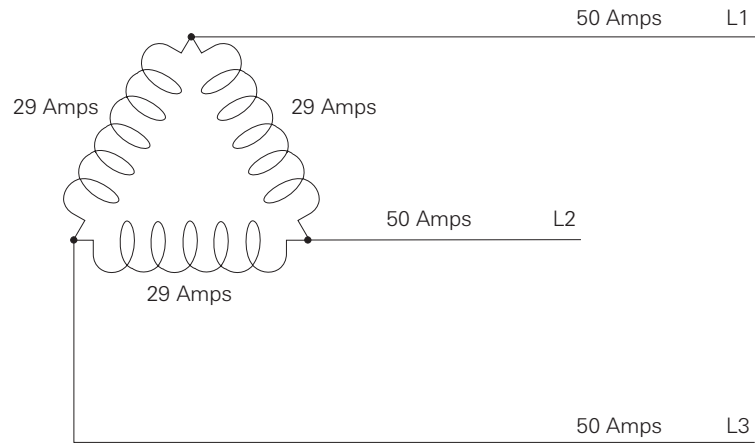

Unbalanced Delta Current

When current is different in all three coils, it is unbalanced. The following diagram depicts an unbalanced system.

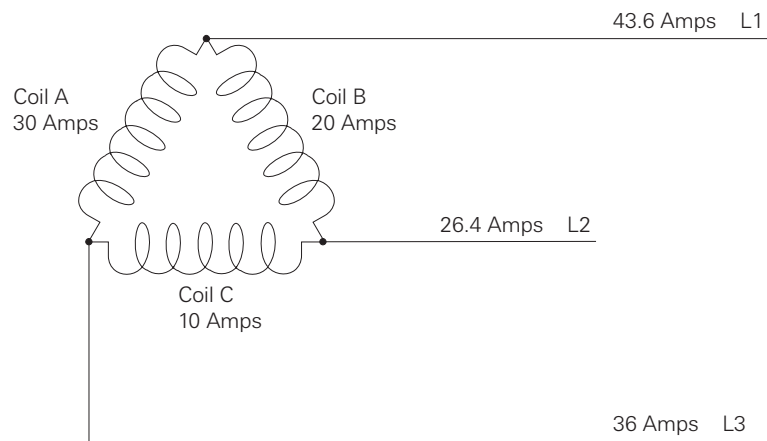

Though current is usually measured with an ammeter, line current of an unbalanced delta transformer can be calculated with the following formulas:

$$I_{L1} = \sqrt{I_A^2 + I_B^2 + (I_A \times I_B)}$$

$$I_{L2} = \sqrt{I_B^2 + I_C^2 + (I_B \times I_C)}$$

$$I_{L3} = \sqrt{I_A^2 + I_C^2 + (I_A \times I_C)}$$

Wye Connections

The wye connection is also known as a star connection. Three transformers are connected to form a "Y" shape. The wye transformer secondary, (shown below) has four leads, three phase connectors, and one neutral. The voltage across any phase (line-to-neutral) will always be less than the line-to-line voltage. The line-to-line voltage is 1.732 times the line-to-neutral voltage. In the circuit below, line-to-neutral voltage is 277 volts. Line-to-line voltage will be 480 volts (277×1.732).

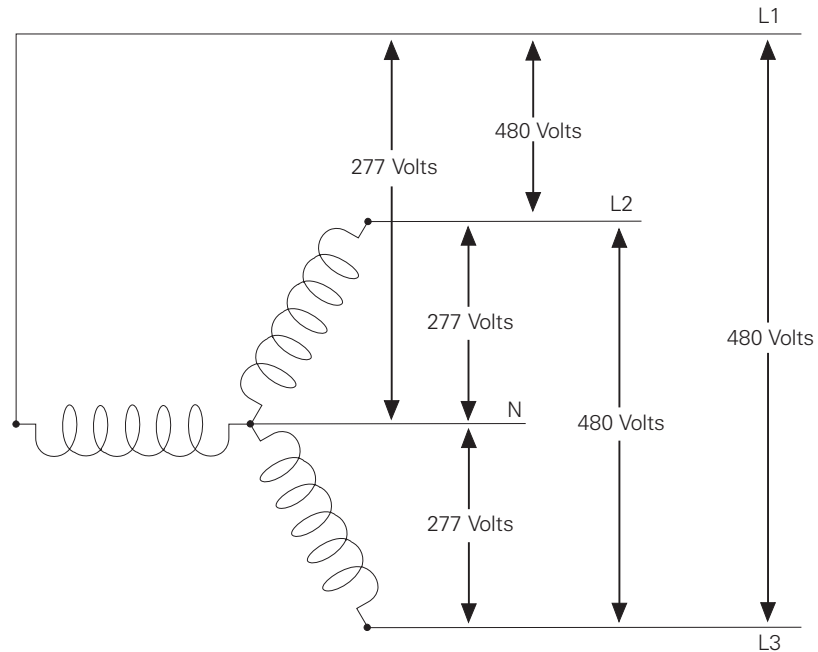

Review 11

1. If the primary of a transformer has more turns than the secondary, it is a _____ transformer.
2. If the primary of a transformer has fewer turns than the secondary, it is a _____ transformer.
3. The secondary voltage of an iron-core transformer with 240 volts on the primary, 40 amps on the primary, and 20 amps on the secondary is _____ volts.
4. A transformer with a 480 volt, 10 amp primary, and a 240 volt, 20 amp secondary will be rated for _____ kVA.
5. A wye connected, three-phase transformer secondary, with 240 volts line-to-line will have _____ volts line-to-neutral.

Review Answers

- Review 1** 1) electron (-), proton (+), neutron (neutral); 2) free electrons; 3) many; 4) a, c, e, g; 5) many, few.
- Review 2** 1) electrons; 2) negative; 3) positive; 4) repel, attract; 5) voltage; 6) b; 7) a.
- Review 3** 1) $I = \frac{E}{R}$; 2) amps, volts, ohms; 3) .5 amps; 4) 45 Ω ; 5) 2 amps; 6) 6 volts, 6 volts; 7) 20 volts, 80 volts.
- Review 4** 1) 5 Ω ; 2) 5.45 Ω ; 3) 3.33 Ω ; 4) 12 volts; 5) 6 amps; 6) 2.4 amps, 1.6 amps.
- Review 5** 1) 12 Ω , 22 Ω ; 2) 40 Ω , 13.33 Ω .
- Review 6** 1) power; 2) $P = E \times I$; 3) 36 watts; 4) iron, north-south; 5) north, south; 6) left, thumb, lines of flux.
- Review 7** 1) sine wave; 2) 120 degrees; 3) one; 4) -129.9 volts; 5) 106.05 volts rms.
- Review 8** 1) 10 mh; 2) 2.5 mh; 3) 2.5 μF ; 4) 25 μF .
- Review 9** 1) reactance; 2) impedance; 3) 3.14 Ω ; 4) c; 5) b; 6) 318.5 Ω ; 7) 11.18 Ω ; 8) 6.4 Ω .
- Review 10** 1) resistive; 2) inductive; 3) capacitive; 4) 1198 Ω , .1 amp; 5) 84.9 milliamps, 1414.2 Ω ; 6) watts; 7) 4 watts;
- Review 11** 1) step-down; 2) step-up; 3) 480 volts; 4) 4.8 kVA; 5) 138.56 volts.

Final Exam

The final exam is intended to be a learning tool. The book may be used during the exam. A tear-out answer sheet is provided. After completing the test, mail the answer sheet in for grading. A grade of 70% or better is passing. Upon successful completion of the test a certificate will be issued.

Questions

1. A material that is a good insulator is
 - a. copper
 - b. aluminum
 - c. silver
 - d. rubber

2. A material with more protons than electrons has a
 - a. negative charge
 - b. positive charge
 - c. neutral charge
 - d. no charge

3. In a simple electric circuit with a 12 volt supply, and a $24\ \Omega$ resistor, current is
 - a. 2 amps
 - b. 5 amps
 - c. 0.2 amps
 - d. 0.5 amps

4. The total resistance in a series circuit containing three, $10\ \Omega$, resistors is
 - a. $10\ \Omega$
 - b. $30\ \Omega$
 - c. $3.33\ \Omega$
 - d. $100\ \Omega$

5. In a 12 volt series circuit where $R_1=10\ \Omega$, $R_2=20\ \Omega$, and $R_3=10\ \Omega$, current flow through R_2 is
 - a. 0.3 amps
 - b. 0.5 amps
 - c. 0.25 amps
 - d. 3.33 amps

14. Total capacitance for a series circuit containing a 2 μF , 4 μF , and 8 μF capacitors is
- a. 14 μF
 - b. 0.875 μF
 - c. 1.14 μF
 - d. 4 μF
15. Total opposition to current flow in an AC circuit that contains both reactance and resistance is called
- a. resistance
 - b. reactance
 - c. impedance
 - d. capacitance
16. In a 60 hertz circuit containing 5 millihenrys of inductance, inductive reactance is
- a. 1.884 Ω
 - b. 1884 Ω
 - c. 0.0005 Ω
 - d. 0.05 Ω
17. In a purely inductive circuit
- a. current leads voltage by 90 degrees
 - b. current lags voltage by 90 degrees
 - c. current and voltage are in phase
 - d. current leads voltage by 30 degrees
18. In a series AC circuit with a 20 Ω resistor and a 10 Ω inductive reactance, impedance is
- a. 30 Ω
 - b. 10 Ω
 - c. 14.1 Ω
 - d. 22.4 Ω
19. A series AC circuit containing more capacitive reactance than inductive reactance is
- a. inductive
 - b. resistive
 - c. capacitive
 - d. in phase
20. An iron-core transformer with 120 volt, 10 amp primary, and 5 amp secondary is a
- a. step down transformer with a 60 volt secondary
 - b. step up transformer with a 240 volt secondary
 - c. step up transformer with a 480 volt secondary
 - d. step down transformer with a 30 volt secondary

quickSTEP Online Courses

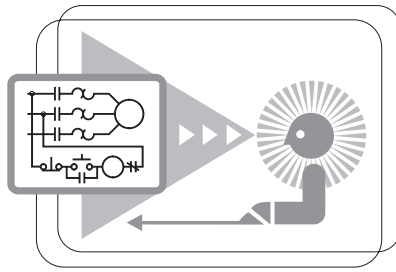

quickSTEP online courses are available at <http://www.sea.siemens.com/step>.

The quickSTEP training site is divided into three sections: Courses, Downloads, and a Glossary. Online courses include reviews, a final exam, the ability to print a certificate of completion, and the opportunity to register in the Sales & Distributor training database to maintain a record of your accomplishments.

From this site the complete text of all STEP courses can be downloaded in PDF format. These files contain the most recent changes and updates to the STEP courses.

A unique feature of the quickSTEP site is our pictorial glossary. The pictorial glossary can be accessed from anywhere within a quickSTEP course. This enables the student to look up an unfamiliar word without leaving the current work area.

